

1 2 3 4 5 6 7 8

Rev No.	Description	Date	Name
A	New Assembly	27/04/10	N. Santini

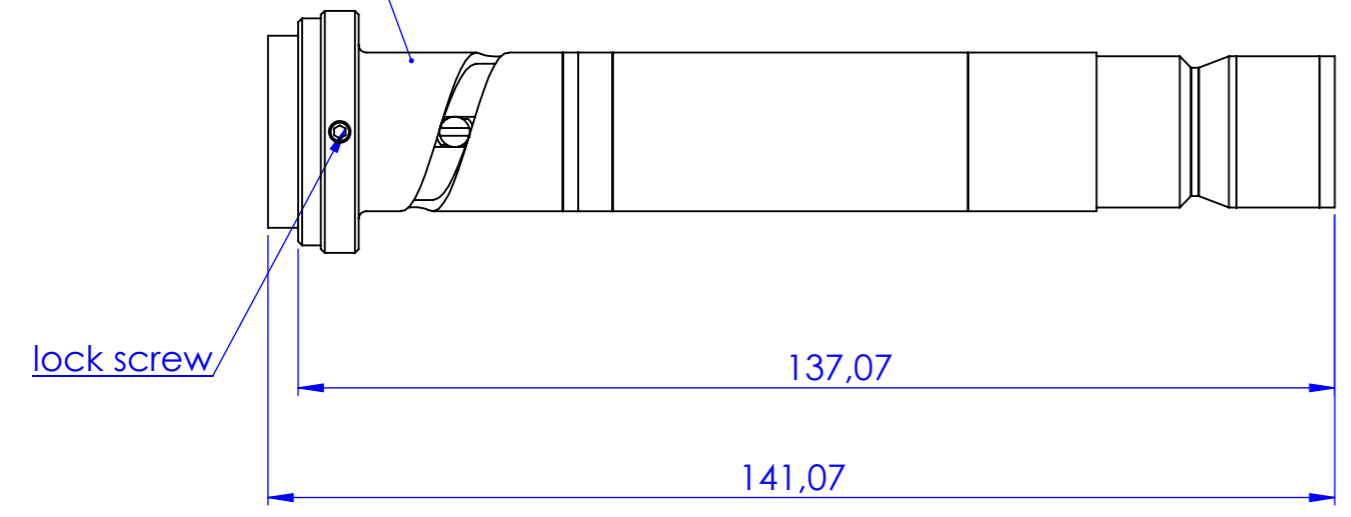
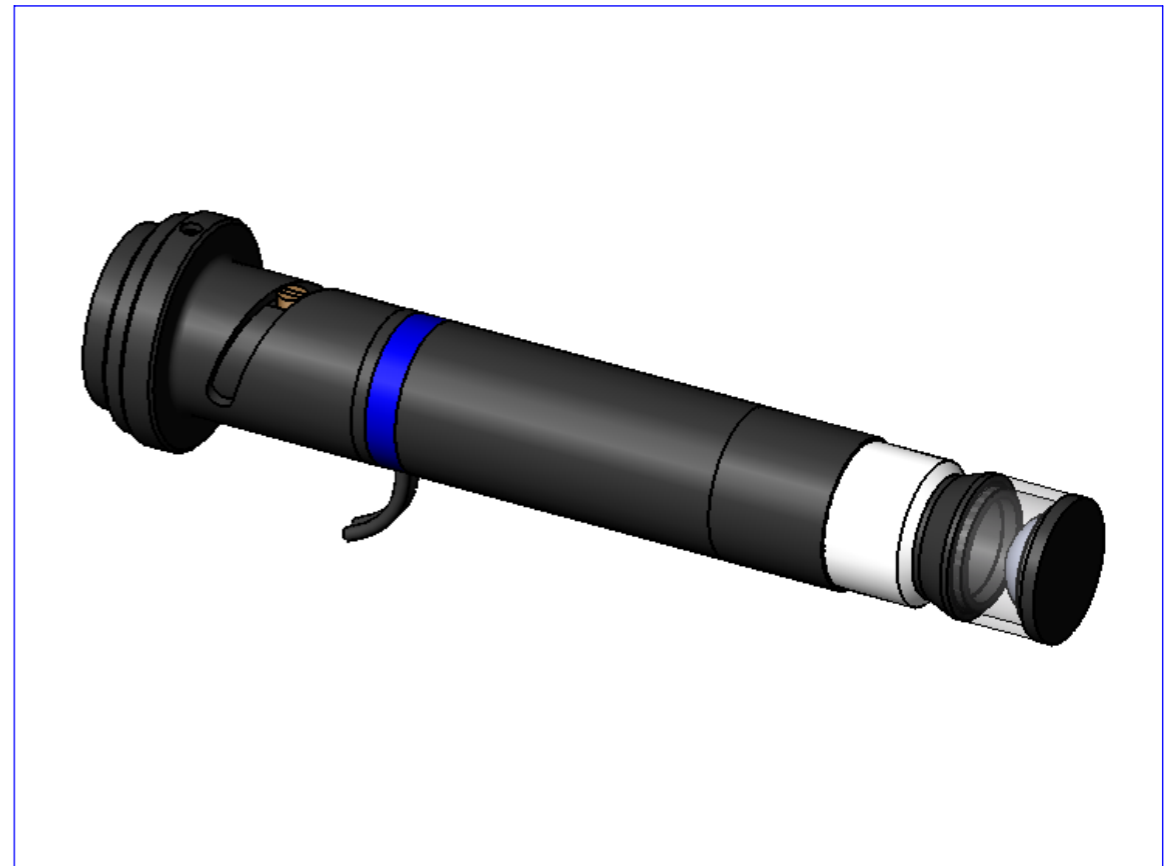
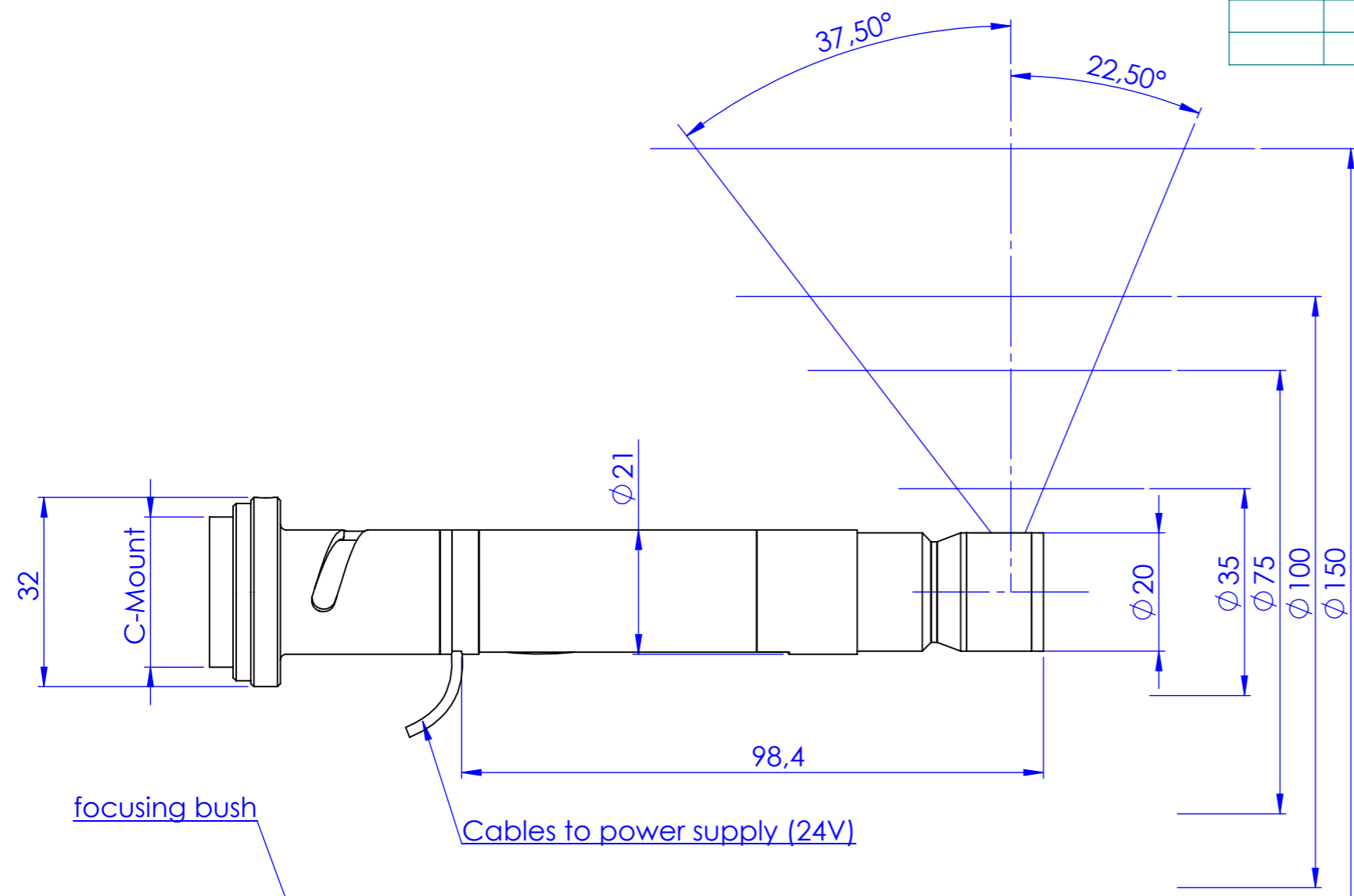

Material	N.A.		Mass	91 g	Scale	1:1
Surface treatment	N.A.		Project-Prod.item/Instrument	PCPB012		
Geometrical tolerance (ISO 2768-2)			Class	K	Undimensioned bevels	0.5x45°
Linear tolerance (ISO 2768-2)			Class	m	Undimensioned radii	R 0.5
0.5 ±3	>3±6	>6±30	>30±120	>120±400	>400±1000	>1000±2000
±0.1	±0.1	±0.2	±0.3	±0.5	±0.8	±1.2
>2000±4000	Date		Name		Drawing No.	Sheet
	Designed	27/04/10	N. Santini		19401-0-A	1/1
	Draw	27/04/10	N. Santini			
	Checked	X	C.Sedazzari			
OPTO ENGINEERING THE TELECENTRIG COMPANY OPTO ENGINEERING S.r.l. - 46100 Mantova Italy - Via Cremona, 29/2 - Tel. +39 0376 263565 - e-mail: info@opto-engineering.com - http://www.opto-engineering.com						

1 2 3 4 5 6 7 8

0 1 2 3 4 5 6 7 8 9 10