

Rev No.	Description	Date	Name

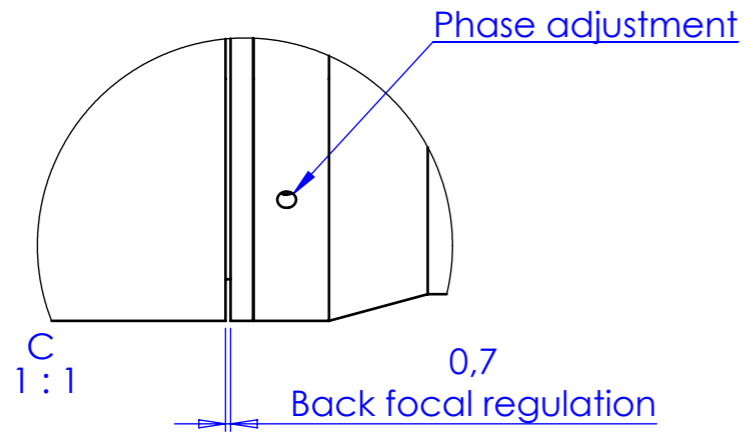
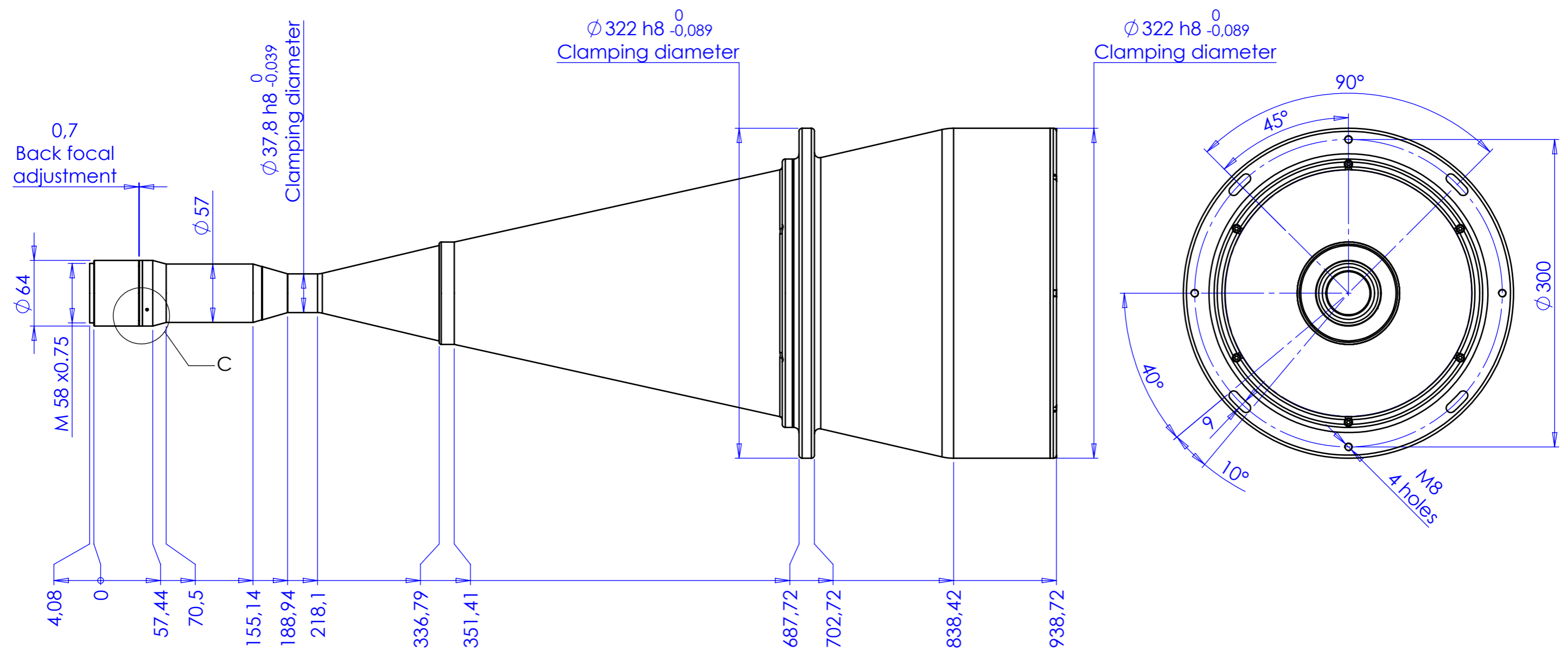

Material	N.A.	Mass	18640 g	Scale	1:4						
Surface treatment	N.A.	Part No.	CO21503								
Geometrical tolerance (ISO 2768-2)	Class	K	Undimensioned bevels	0,5x45°	Description TC16M240-Q						
Linear tolerance (ISO 2768-2)	Class	m	Undimensioned radii	R 0,5							
0,5 ±3	>3± 6	>6± 30	>30± 120	>120 ±400	>400± 1000	>1000 ±2000	>2000 ±4000	Date	Name	Drawing No.	Sheet
±0,1	±0,1	±0,2	±0,3	±0,5	±0,8	±1,2	±2	13/11/2014	Santini	DP 21503-A	1/1
								05/05/2015	Rodella		
								Checked			
OPTO ENGINEERING S.r.l. - Mantova Italy - Tel. +39 0376 699111 - www.opto-engineering.com											

Secret and confidential - All rights reserved -
No copy, dissemination or circulation is allowed unless
specifically authorized in writing by OPTO ENGINEERING
S.r.l. - Any violation shall be legally prosecuted.