



# TCCR4M056-E

CORE系列远心镜头, 适用于4/3"探测器, 放大倍率0.314 x, M42x1 FD=16

OPTO ENGINEERING

## 参数

Part number		TCCR4M056-E
放大	(x)	0.314
Image shape dimension (8)	( $\varnothing$ , x mm)	$\varnothing=22.0$ , x=19.2
Phase adjustment (7)		Yes

## 物方视场

KAI-2020, 14.8 mm对角线, 11.84 x 8.88 (w x h)	(mm x mm)	37.7 x 28.3
KAI-04050, 16 mm对角线, 12.8 x 9.6 (w x h)	(mm x mm)	40.8 x 30.6
KAI-4022/4021, 21.5 mm对角线, 15.2 x 15.2 (w x h)	(mm x mm)	48.4 x 48.4
KAI-08050, 22.6 mm对角线, 18.1 x 13.6 (w x h)	(mm x mm)	57.6 x 43.3

## 光学规格

工作距离 (1)	(mm)	157.80
工作F值 (2)		16
典型 (最大) 远心度 (3)	(deg)	< 0.05 (0.10)
典型 (最大) 畸变 (4)	(%)	< 0.04 (0.10)
景深 (5)	(mm)	12.0
CTF@ 50 lp/mm	(%)	> 40

## 机械性能

接口 (6)		M42x1
A	(mm)	94
B	(mm)	115
C	(mm)	204
质量	(g)	1759

## 兼容产品

LTCLCR056-x, CMHOCR056, CMPTCR056, LTCLHP056-x

## 注释

- Working distance: distance between the front end of the mechanics and the object. Set this distance within +/- 3% of the nominal value for maximum resolution and minimum distortion.
- Working F-number (wF/#): the real F-number of a lens when used as a macro. Lenses with smaller apertures can be supplied on request.
- Maximum slope of chief rays inside the lens: when converted to milliradians, it gives the maximum measurement error for any millimeter of object displacement. Typical (average production) values and maximum (guaranteed) values are listed.
- Percent deviation of the real image compared to an ideal, undistorted image: typical (average production) values and maximum (guaranteed) values are listed.
- At the borders of the field depth the image can be still used for measurement but, to get a perfectly sharp image, only half of the nominal field depth should be considered. Pixel size used for calculation is 5.5  $\mu\text{m}$ .
- In case the of vignetting, FOV dimensions are indicated with " $\varnothing =$ , x=", where " $\varnothing =$ " stands for diameter and "x=" indicates the nominal FOV height and length (see [Tech Info](#) for related drawing).
- Indicates the availability of an integrated camera phase adjustment feature.
- Indicates the dimensions and shape of image, where " $\varnothing =$ " stands for diameter and "x=" indicates the nominal image height and length (see [Tech Info](#) for related drawing)

## 兼容产品

 **LTCLHP 系列**  
高性能远心照明器

<b>LTCLHP056-R</b>	Telecentric HP illuminator, beam diameter 70 mm, red
<b>LTCLHP056-G</b>	Telecentric HP illuminator, beam diameter 70 mm, green

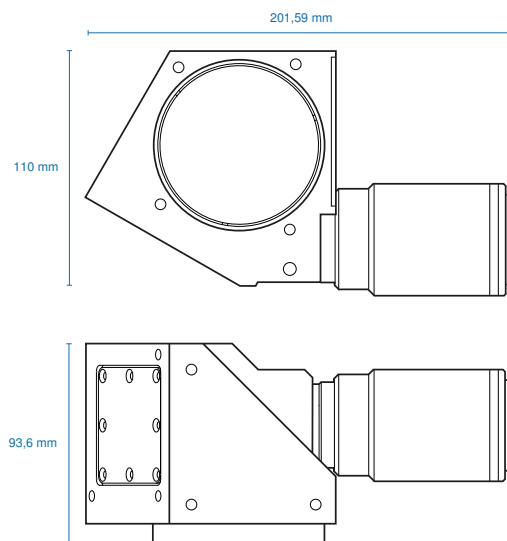
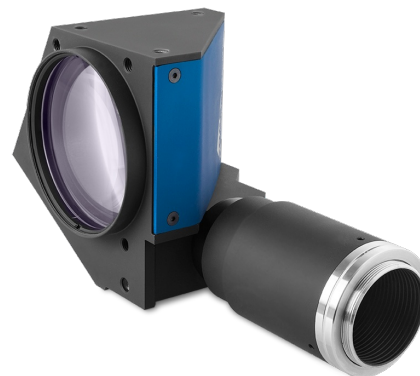

<b>LTCLHP056-B</b>	Telecentric HP illuminator, beam diameter 70 mm, blue
<b>LTCLHP056-W</b>	Telecentric HP illuminator, beam diameter 70 mm, white



**LTCLHP CORE 系列**  
超紧凑型远心照明器

<b>LTCLCR056-R</b>	CORE远心照明器, 光束直径70 mm, 红色
<b>LTCLCR056-G</b>	CORE远心照明器, 光束直径70 mm, 绿色
<b>LTCLCR056-W</b>	CORE远心照明器, 光束直径70 mm, 白色



**CMHOCR 系列**  
夹持机构 CORE 系列

<b>CMHOCR056</b>	适用于CORE远心镜头和 $\varnothing$ 56mm照明器的夹持机构
------------------	---



**CMPTCR 系列**  
安装板CORE系列

<b>CMPTCR056</b>	设计用于CORE远心镜头和 $\varnothing$ 56mm照明器的机械部件
------------------	--