



TCCR4M096-F

CORE系列远心镜头, 适用于4/3"探测器, 放大倍率0.186 x, F接口

参数

Part number		TCCR4M096-F
放大	(x)	0.186
Image shape dimension (8)	(\varnothing , x mm)	$\varnothing=22.5$, x=18.6
Phase adjustment (7)		Yes

物方视场

KAI-2020, 14.8 mm对角线, 11.84 x 8.88 (w x h)	(mm x mm)	63.5 x 47.6
KAI-04050, 16 mm对角线, 12.8 x 9.6 (w x h)	(mm x mm)	68.7 x 51.5
KAI-4022/4021, 21.5 mm对角线, 15.2 x 15.2 (w x h)	(mm x mm)	81.6 x 81.6
KAI-08050, 22.6 mm对角线, 18.1 x 13.6 (w x h)	(mm x mm)	97.1 x 73.0

光学规格

工作距离 (1)	(mm)	278.62
工作F值 (2)		16
典型 (最大) 远心度 (3)	(deg)	< 0.05 (0.10)
典型 (最大) 畸变 (4)	(%)	< 0.04 (0.10)
景深 (5)	(mm)	34.2
CTF@ 50 lp/mm	(%)	> 35

机械性能

接口 (6)		F
A	(mm)	139
B	(mm)	175
C	(mm)	225
质量	(g)	4441

兼容产品

LTCLCR096-x, CMHOCR096, CMPTCR096, LTCLHP096-x

注释

- Working distance: distance between the front end of the mechanics and the object. Set this distance within +/- 3% of the nominal value for maximum resolution and minimum distortion.
- Working F-number (wF/#): the real F-number of a lens when used as a macro. Lenses with smaller apertures can be supplied on request.
- Maximum slope of chief rays inside the lens: when converted to milliradians, it gives the maximum measurement error for any millimeter of object displacement. Typical (average production) values and maximum (guaranteed) values are listed.
- Percent deviation of the real image compared to an ideal, undistorted image: typical (average production) values and maximum (guaranteed) values are listed.
- At the borders of the field depth the image can be still used for measurement but, to get a perfectly sharp image, only half of the nominal field depth should be considered. Pixel size used for calculation is 5.5 μ m.
- In case the of vignetting, FOV dimensions are indicated with " $\varnothing =$, x =", where " $\varnothing =$ " stands for diameter and "x=" indicates the nominal FOV height and length (see [Tech Info](#) for related drawing).
- Indicates the availability of an integrated camera phase adjustment feature.
- Indicates the dimensions and shape of image, where " $\varnothing =$ " stands for diameter and "x=" indicates the nominal image height and length (see [Tech Info](#) for related drawing)

兼容产品

 **LTCLHP 系列**
高性能远心照明器

LTCLHP096-G	Telecentric HP illuminator, beam diameter 120 mm, green
LTCLHP096-R	Telecentric HP illuminator, beam diameter 120 mm, red

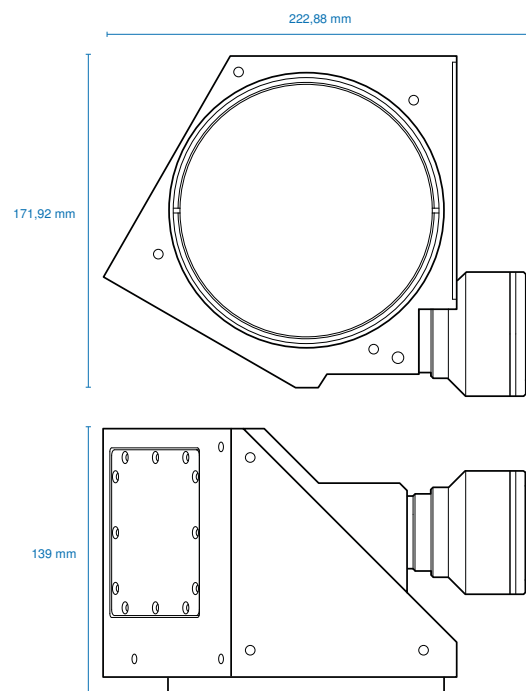

LTCLHP096-B	Telecentric HP illuminator, beam diameter 120 mm, blue
LTCLHP096-W	Telecentric HP illuminator, beam diameter 120 mm, white



LTCLHP CORE 系列
超紧凑型远心照明器

LTCLCR096-R	CORE远心照明器, 光束直径120 mm, 红色
LTCLCR096-G	CORE远心照明器, 光束直径120 mm, 绿色
LTCLCR096-W	CORE远心照明器, 光束直径120 mm, 白色



CMHOCR 系列
夹持机构 CORE 系列

CMHOCR096	适用于CORE远心镜头和Ø 96mm照明器的夹持机构
------------------	----------------------------



CMPTCR 系列
安装板CORE系列

CMPTCR096	设计用于CORE远心镜头和Ø 96mm照明器的机械部件
------------------	-----------------------------